



SUN YEH OM4 400Nm ELECTRIC ACTUATOR



SPECIFICATIONS

1	Power consumption:	120W
2	Max Torque:	400Nm
3	Speed:	16 Seconds /90 degrees
4	Weight:	20KG
5	Manual Override:	Hand-Wheel
6	Mounting Flange:	ISO 5211 F07 x 22MM Star
7	Housing:	IP67 Nema 4X
8	Approval:	CSA and RoHS, CE marked
9	Duty Cycle:	30% standard (75% option)

ENCLOSURE:

- IP67 \ NEMA 4X : Water-proof and dust-proof enclosure.
- Material : Dry powder coating aluminum alloy.

MOTOR:

- Standard extended duty cycle induction motor. F (Standard) or H (Optional) insulation class for all models.
 - Built-in thermal protection prevents motor burning out.
- AC motor: 125±5°C/257±9°F
 DC motor: 90±5°C/194±9°F

DUTY CYCLE:

- OM-3: 30% duty cycle (Standard Model)
- OM-3: 75% duty cycle (Optional)

WORKING CONDITIONS:

- Ambient temperature: -30°C ~ +65°C / -22°F ~ +149°F
- The humidity: 30% ~ 95%

POSITION INDICATION:

- All models have continuous mechanism position indicator on the top of actuator cover.

MANUAL OVERRIDE:

- Non-clutch design, the manual operation can be operated without any lever, clutch or brake upon power outage.
- When electric motor is operating, hand-wheel won't rotate for personal safety purpose.

GEAR TRAIN:

- High alloy steel gear trains provide self-locking function to avoid valve back drive.
- Gear trains have been already lubricated sufficiently with anti-high temperature lubricant at the factory.

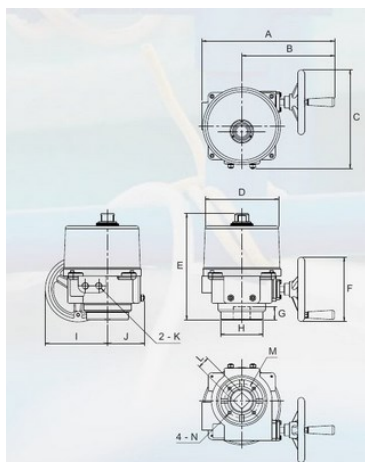

DIMENSIONS															
Model No.	A	B	C	D	E	F	G	H	I	J	K	L	M	N	Flange Type
OM-4~OM-6	394	275	292.5	∅217	317	∅191	40	∅125	184	110	1/2PS	35	∅102	M10*1.5	F10