





TYPE MARS: M33





TM
MARS

We Make Automation Easy

SERIES 36



**DIRECT MOUNT
MULTI PORT
3-WAY / 4-WAY BALL VALVES
1/4" TO 4" (DN 8 TO DN 100)**

**DIRECT MOUNTING OF
ACTUATOR TO VALVES**

DESIGN ADVANTAGES

- **ISO 5211 DIRECT MOUNT PAD**
Allows direct mounting of pneumatic and electric actuators, no brackets and couplings needed. easy and low cost for automated service.
- **LIVE LOADED STEM PACKING**
- **BLOW OUT PROOF STEM**
- **COST EFFICIENT**
One valve can replace two or more valves, reduces the number of valves in piping system
- **ANTI-STATIC DEVICE**
- **INVESTMENT CAST BODY CONSTRUCTION**

SPECIFICATIONS

Construction : Full Bore and Reduced Bore
Available T or L ports in 3-Way and 4-Way configurations

Size : 1/4" to 4" (DN 8 to DN 100)

End Conn. : Screwed, Socket Weld, Butt Weld, Flanged Ends.

Body : CF8M, WCB / 1.4408, 1.0619









Ball & Stem : 316 S.S.

Seat : Reinforced Teflon

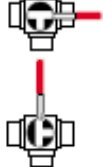

Rating : 1000 PSI

Temperature : -60° F ~ 420° F (R-PTFE)



FLOW PATTERNS

STANDARD CONFIGURATIONS	OTHER AVAILABLE CONFIGURATIONS						
T5-90°	T4-90°	T3-90°	T6-90°	T1-180°	T2-180°	T3-180°	T7-180°
							

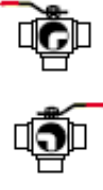
3 WAY " L " PORT

STANDARD CONFIGURATIONS	OTHER CONFIGURATIONS			VERTICAL "L"
L2-90°	L1-180°	L3-180°	L4-180°	
				

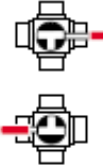
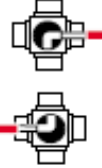
4 WAY

"T" PORT	"L" PORT	"X" PORT
T8-180°	L5-180°	X-90°
		



ALLVALVES SERIES MARS – 88 SERIES BALL VALVE

www.allvalves.co.uk

TYPE MARS: M88

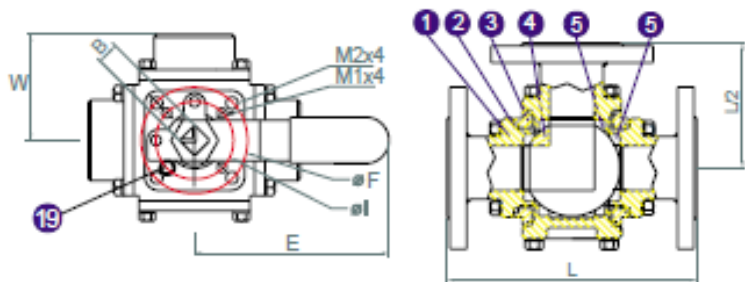

END CAP TYPE : FLANGE END(ANSI 150LBS, PN16)

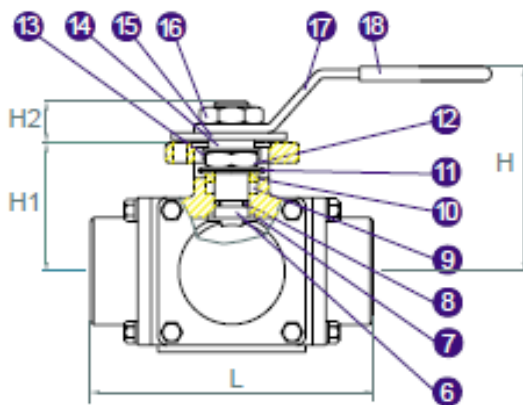

•End cap type : threaded , socket weld , butt weld

MATERIALS LIST

NO.	PART NAME	MATERIAL	QTY
1	End Cap	A351 Gr. CF8M A216 Gr. WCB	3
2	Gasket	PTFE	4
3	Body	A351 Gr. CF8M A216 Gr. WCB	1
4	Ball	SS 316	1
5	Seat	15% CABON+PTFE	4
6	Stem	SS 316	1
7	Stem Seal	RPTFE	1
8	O-Ring	VITON	1
9	Stem Packing	PTFE	1
10	Gland	SS 304	1
11	Belleville Washer	SS 301	2
12	Stem Nut	SS 304	1
13	Nut Stop	SS 304	1
14	Space Washer	SS 304	1
15	Lock Saddle	SS 304	1
16	Handle Nut	SS 304	1
17	Handle	SS 304	1
18	Handle sleeve	Vinyl	1
19	Stop Pin	SS 304	1

DIMENSIONS (mm)

SIZE	B	E	H	H1	H2	øI	øF	L	*L	*L	M1	M2	W	WT.(kg)	*WT.(kg)	*WT.(kg)	ISO5211
1/4"	9	130	62	38.5	10	36	42	88	/	/	6.0	6.0	44	1.26	/	/	F03/F04
3/8"	9	130	62	38.5	10	36	42	88	/	/	6.0	6.0	44	1.20	/	/	F03/F04
1/2"	9	130	64	41	10	36	42	105	153	160	6.0	6.0	52.5	2.00	3.43	4.30	F03/F04
3/4"	11	165	82	49	13	42	50	112	168	177	6.0	7.1	55.5	2.60	4.41	5.49	F04/F05
1"	11	165	89	55	13	42	50	128	190	190	6.0	7.1	64	3.60	5.90	7.39	F04/F05
1 1/4"	14	205	98	63	17	50	70	140	/	/	7.1	9.2	70	/	/	/	F05/F07
1 1/2"	14	205	108	74	17	50	70	160	221	234	7.1	9.2	80	8.32	12.38	14.54	F05/F07
2"	17	325	140	93	22	70	102	192	254	273	9.2	11.4	96	15.34	21.33	23.73	F07/F10

• The above dimensions are for valve sizes 1/4" to 2" Full Bore only.
For valve sizes 2 1/2" to 4" and Reduced Bore, Please consult factory.

* Dimension for 150LBS

* Dimension for PN16

HOW TO ORDER

VALVE TYPE		PORT DESIGN		PORT CONFIGURATION			VALVE SIZE				BODY MATERIAL		SEAT	
36-10	Threaded End	F	Full Bore	T1	L1	X	01	1/4"	S	CF8M	P	PTFE		
36-20	Socket Weld End	R	Reduced Bore	T2	L2		02	3/8"	W	WCB	R	R-PTFE		
36-30	Butt Weld			T3	L3		03	1/2"			S	50/50 S. S. filled PTFE		
36-40	ANSI 150#			T4	L4		04	3/4"			C	Carbon filled PTFE		
36-40	ANSI 150#			T5	L7		05	1"			M	MG1241		
36-50	DIN PN 10/16			T6			06	1 1/4"						
			T7			07	1 1/2"							
			T8			08	2"							
						09	2 1/2"							
						10	3"							
						11	4"							

Tel: 01386 552369

Fax: 01386 554227

sales@allvalves.co.uk

Allvalves Online Ltd, Automation House, Unit 2, Pershore, WR10 2DF UK